

SVPO.S08 Valve Series

SAE Cartridge - 250 bar

Directional Valve - 3/2 Spool type

Description

A Solenoid operated, 3 way 2 positions, spool type, direct acting, screw-in hydraulic directional cartridge valve.

In the de-energized mode, the SVPO.S08 allows flow bidirectionally between ports 1 and 2, while blocking flow at 3.

In the energized mode, bidirectional flow is allowed between ports 2 and 3, while flow is blocked at 1.

Even if port 1 may be fully pressurized, it is not intended to be used as the inlet.

The rigid design using a 1-piece body contributes to minimize the effect of eccentricities in cavity and provides great reliability.

Low pressure drop thanks to optimized flow path.

Technical Features

All external surfaces are zinc plated and corrosion-proof.

All valve parts are made of high strength steel. Spool and cage are hardened and super-finished to ensure minimal wear and extended service life.

Coil seals protect the solenoid system.

Manual override option.

Industry SAE common cavity.



Symbols

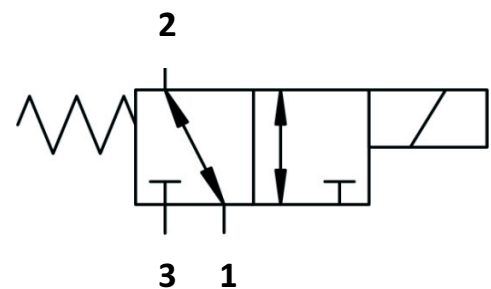

Performance Details

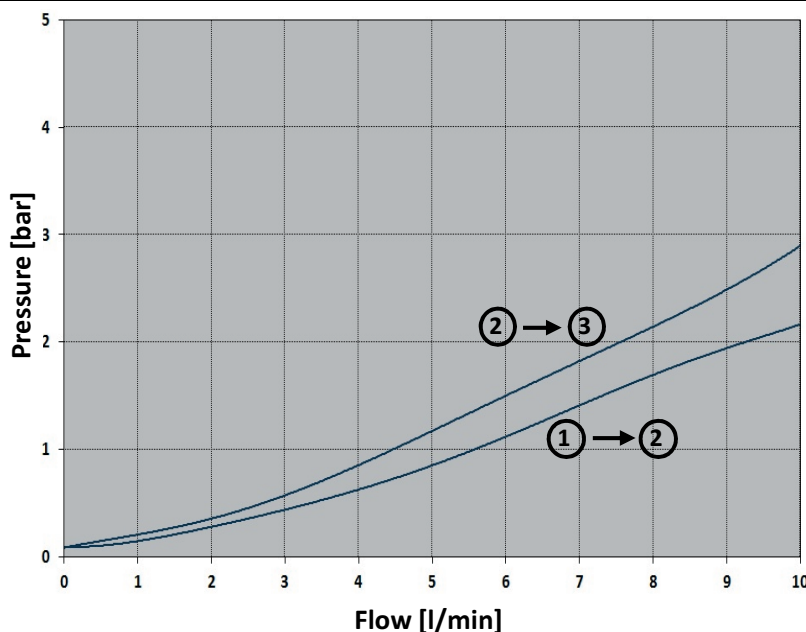

Technical Data

Maximum operating pressure: 250 bar

Maximum flow: 10 l/min

Internal leakage: max 85 cc/min @ 250 bar

Temperature: -30°C to 110°C

Fluids: Mineral-based or synthetics with lubricating properties at viscosities of 7.4 to 420 cSt

Minimum pull-in voltage: 85% of nominal

Orientation: no restrictions

Installation torque: 40-45 Nm

Seal kit code: SK.035 and SK.027 (coil)

Weight: 0.140 kg

NOTE: The performance chart illustrates flow handling capacity 1 to 2 (de-energized) and 2 to 3 (energized).

P/Q curves are recorded at $T_{oil} = 40^{\circ}C$ and 46 cSt

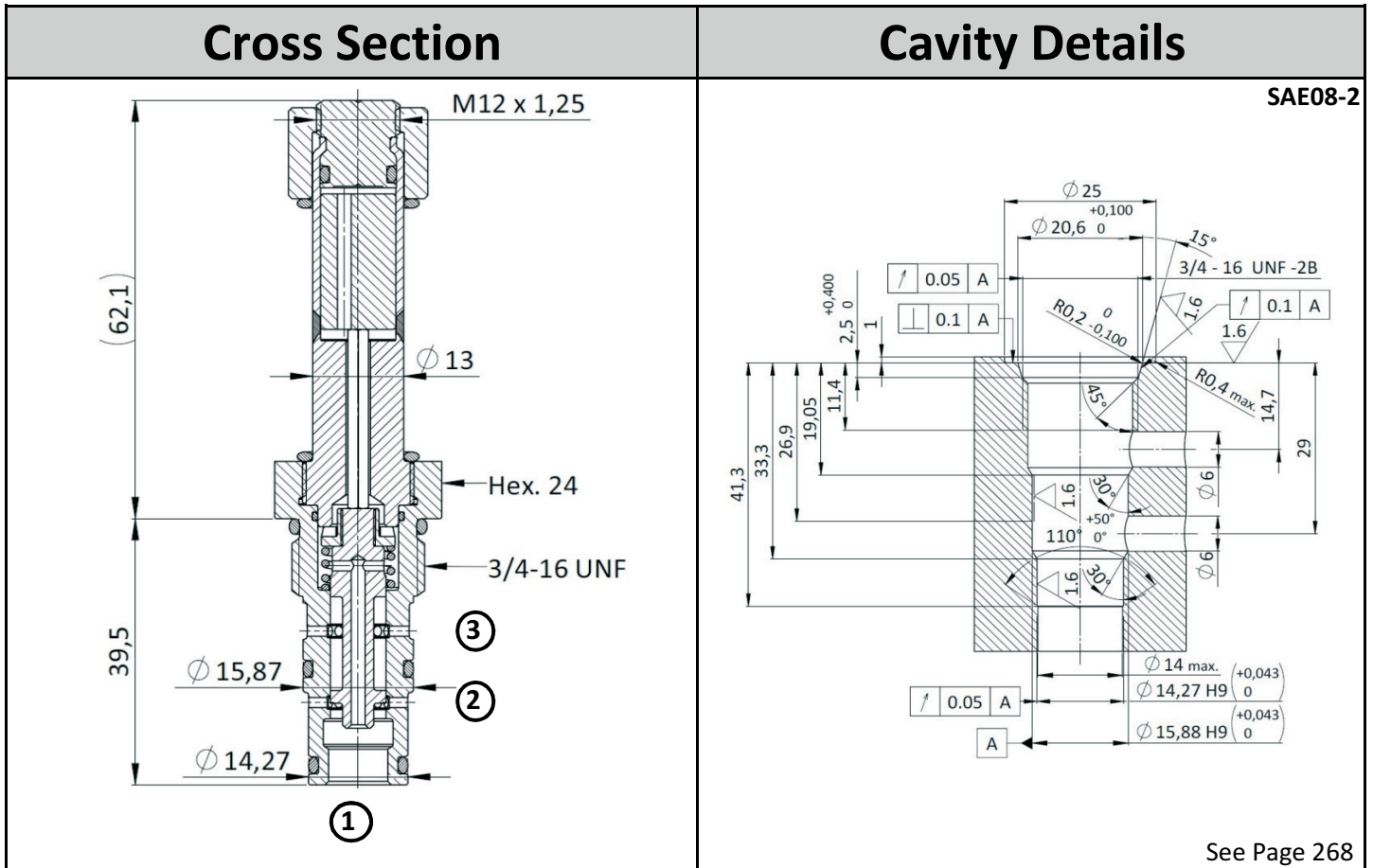

Ordering Code

S	V	P	0	.	S	0	8	.	0	*	.	2	0	0	
↓ Valve Basic Code				↓ Cavity S08 = UNF - SAE08-2				↓ Flow path 1 and 2 connected, 3 blocked (de-energized) 2 and 3 connected, 1 blocked (energized)		↓ Manual override (see table below for available options and page 257 for more details)			↓ Marking 0 = Standard factory marking Customized markings can be done upon request		

Manual Override		Coil
Model Code	Type of override	<p>Use 18W coil to operate this valve. For more details see page 259.</p>
0	No override	
3	Push pin	
4	Push knob	
5	Screw	

Specifications may change without notice.