

Check Valve Ball Type

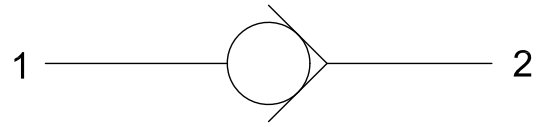

- $Q_{(max)}=40$ lpm , $P_{(max)}=350$ bar
- Screw -in Cartridge,
- Direct Acting , Ball Type Design

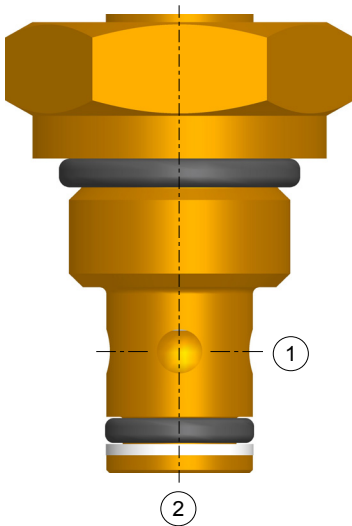

- Allows Free Flow from **Port #2**→ **Port #1**.
- Blocks Flow from **Port #1**→ **Port #2** - Acts as **Load holding Device**.
- Available in **Leakproof screw adjustment / Fixed setting cap**.
- Can be fitted in **line mounting bodies**.
- All external parts are **zinc plated ,chromated (CrVI-Free)**.
- Designed in accordance to **Industry common Cavities**.

1. Description -

SCB series cartridge valves are **Screw-in, Cartridge Type, Ball Type, Hydraulic Check Valves**. This cartridge are used for Blocking or Holding load in hydraulic system. This type of Check Valve allows free flow from Port #2 to Port#1. While blocking flow from Port #1 to Port#2- can be used for holding load at this position.

All external parts of this cartridge are Zinc-plated and chromated (CrVI-free). All Valve parts are made up of high strength steel.

Check Valve
Ball Type

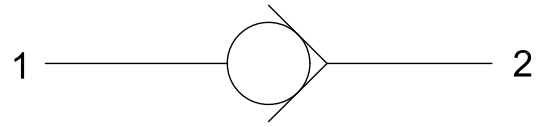

2. Technical Data :

S.no.	General Specification	Values
1.	DESIGNATION	CHECK VALVE ,BALL TYPE
2.	MOUNTING METHOD	S08-2 CAVITY
3.	MAXIMUM OPERATING PRESSURE	350 BAR
4.	MAXIMUM FLOW	40 LPM
5.	MAXIMUM INTERNAL LEAKAGE	0.10 CC/MIN
7.	OPERATING TEMPERATURE	-30° TO +110° C
9.	HYDRAULIC FLUID	MINERAL OILS WITH LUBRICATING PROPERTIES AT 15.....250 MM ² /SEC
10.	MINIMUM FLUID CLEANINESS	ISO CLASS 20/18/15
11.	WEIGHT	0.12 KG
12.	INSTALLATION TORQUE	45-55 N/M

Check Valve Ball Type

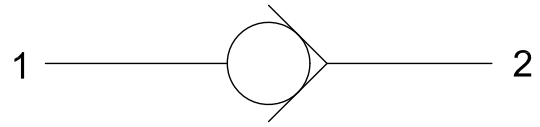

3. P-Q Characteristics :

Note: The Performance Chart shows Flow handling capacity at specific pressure setting P/Q Curve is recorded at Temp_{oil} = 40° C at 46 cst.

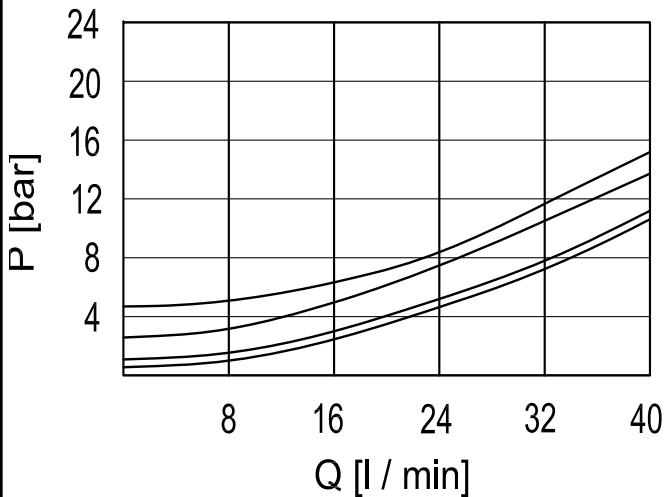

4. Dimensioning :

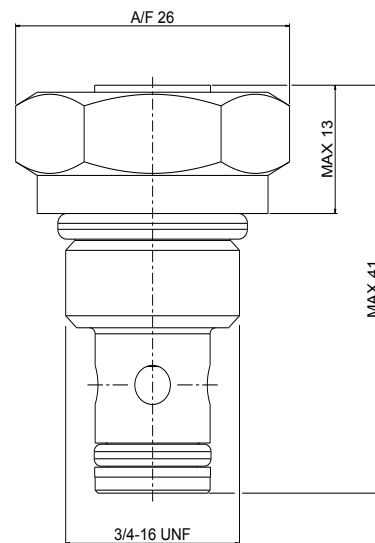

5. Ordering Code :

SCB - 08 - X - XXX

Valve basic code

Cavity Type = 3/4" -16 UNF
METRIC CAVITY AVAILABLE ON
REQUEST

Housing & Ports

C : Cartridge only
XB1 : 1/4" BSP
XB6 : SAE #6

A : Aluminium Housing
S : Steel Housing

Cracking Pressure (bar)

1 : 0.5 bar
2 : 1 bar
3 : 2 bar
4 : 3 bar