

RVQ0.S10 Valve Series

SAE10 Cartridge - 420 bar

Pilot Operated - Spool Type

Description

A screw-in, cartridge style, pilot operated (2-stage), spool type, normally closed, hydraulic relief valve.

When the pressure at the Inlet (1) reaches the valve setting, the pilot poppet starts to open from its seat and determines the shifting of the main stage poppet (spool type) that throttles oil flow to tank (2).

The cartridge offers smooth transition in response to load changes in demanding hydraulic circuits.

Fast, smooth response and limited hysteresis.

Technical Features

All external surfaces are zinc plated and corrosion-proof.

All valve parts are made of high strength steel. Spool and cage are hardened and micron finished in order to guarantee minimal wear and to extend service life.

Adjustment screw cannot be backed out of the valve.

Optional spring ranges to 420 bar (6100 psi)

Back pressure on the tank port (port 2) is directly additive to the valve setting at a 1:1 ratio.

Industry common cavity.



Symbols

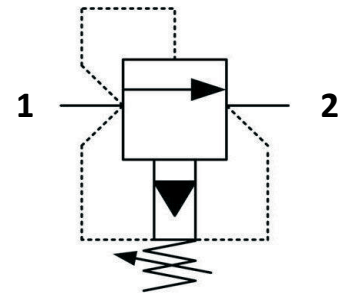

Performance Details

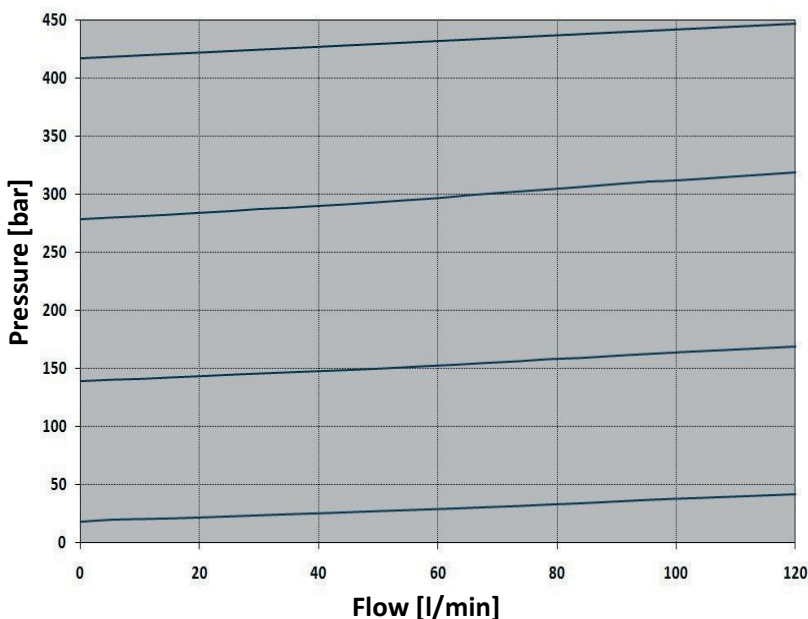

Technical Data

Maximum operating pressure: 420 bar

Maximum flow: 120 l/min

Maximum internal leakage: 100 cc/min to 90% of nominal set point

Factory pressure settings established @5 l/min

Reseat pressure: nominal 90% of crack pressure

Temperature: -30°C to 110°C

Fluids: Mineral-based or synthetics with lubricating properties at viscosities of 7.4 to 420 cSt

Orientation: no restrictions

Installation torque: 55-65 Nm

Seal kit code: SK.001

Weight: 0.196 kg

NOTE: The performance chart illustrates flow handling capacity at maximum setting for each spring range option.

P/Q curves are recorded at $T_{oil} = 40^\circ\text{C}$ and 46 cSt

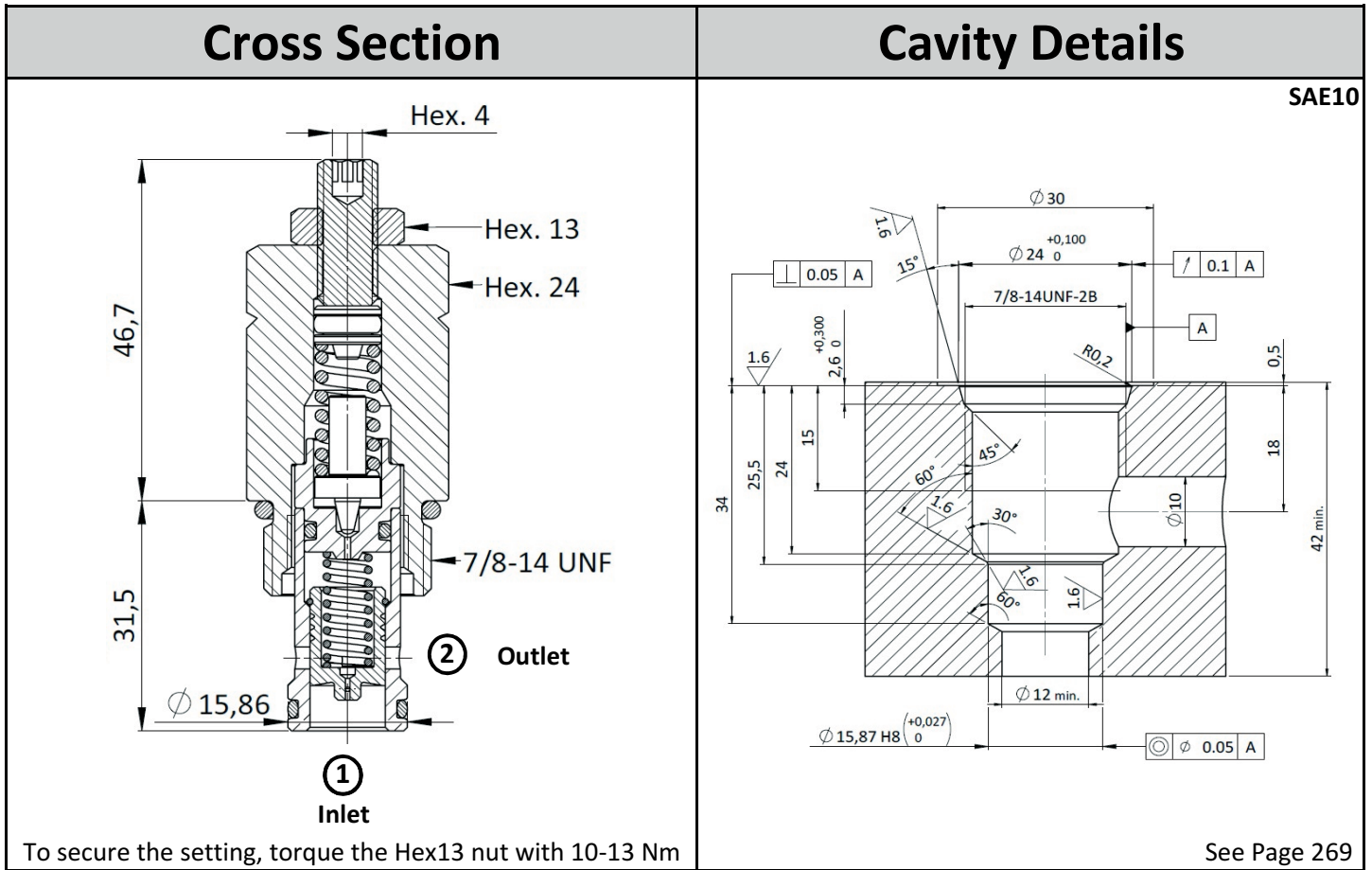

Ordering Code

R V Q 0 . **S 1 0** . **0 *** . *** * ***

↓

Valve Basic Code

←

Cavity

S10 = UNF - SAE10
Metric cavity available upon request

→

Pressure setting in [bar]

000 = no specific setting required

→ **Spring Range** (see table below for available options)

→

Marking

0 = Standard factory marking
Customized markings can be done upon request

Spring Ranges		Options
Spring Model Code	Pressure Setting Range [bar]	<p>Plastic tamper proof cap. Ordering code: CTP.003</p>
Y	20-280	
N	141-280	
B	281-420	

Specifications may change without notice.