

PO Relief and Anti-cavitation Valves

RVP0.M26 Valve Series

METRIC Cartridge - 420 bar

Pilot Operated with anticavitation - Poppet Type

Description

The RVP valve combines in one compact cartridge the typical function of relief valve and anticavitation through the check valve. It's a screw-in, pilot operated (2-stage), poppet type, normally closed valve. When the pressure at the Inlet (1) reaches the valve setting, the pilot poppet starts to open from its seat and determines the shifting of the main stage poppet that throttles oil flow to tank (2). In the free reverse flow function a light bias spring allows for ease of flow passage from side to nose (2 to 1). The cartridge offers smooth transition in response to load changes in demanding hydraulic circuits. Smooth response, reduced pressure rise and limited hysteresis.

Technical Features

All external surfaces are zinc plated and corrosion-proof. All valve parts are made of high strength steel. Poppets are hardened and micron finished in order to guarantee minimal wear and to extend service life. Adjustment screw cannot be backed out of the valve. Spring range up to 420 bar (6100 psi). Back pressure on the tank port (port 2) is directly additive to the valve setting at a 1:1 ratio. Metric cavity.



Symbols

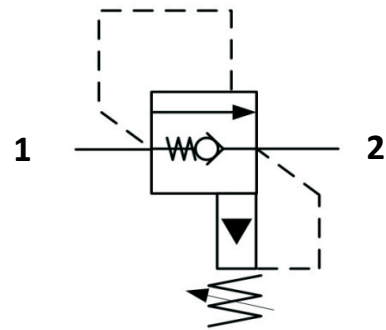

Performance Details

**Pressure Relief function
(side to nose)**

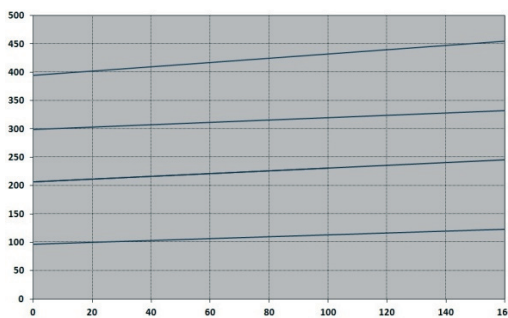

**Anti-cavitation function
(nose to side)**

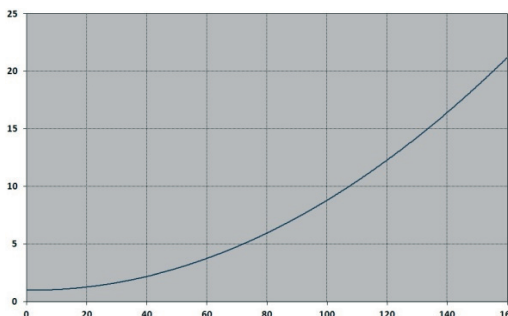

Technical Data

Maximum operating pressure: 420 bar
 Maximum flow: 150 l/min
 Maximum internal leakage: 1 cc/min @ 100 bar
 Factory pressure settings established @ 10 l/min
 Reseat pressure: nominal 90% of crack pressure
 Anti-cav cracking pressure: < 1.5 bar
 Temperature: -30°C to 110°C
 Fluids: Mineral-based or synthetics with lubricating properties at viscosities of 7.4 to 420 cSt
 Orientation: no restrictions
 Installation torque: 70-80 Nm
 Seal kit code: SK.055
 Weight: 0.195 kg

NOTE: The performance chart illustrates flow handling capacity at various settings.

P/Q curves are recorded at $T_{oil} = 40^\circ\text{C}$ and 46 cSt

Cross Section

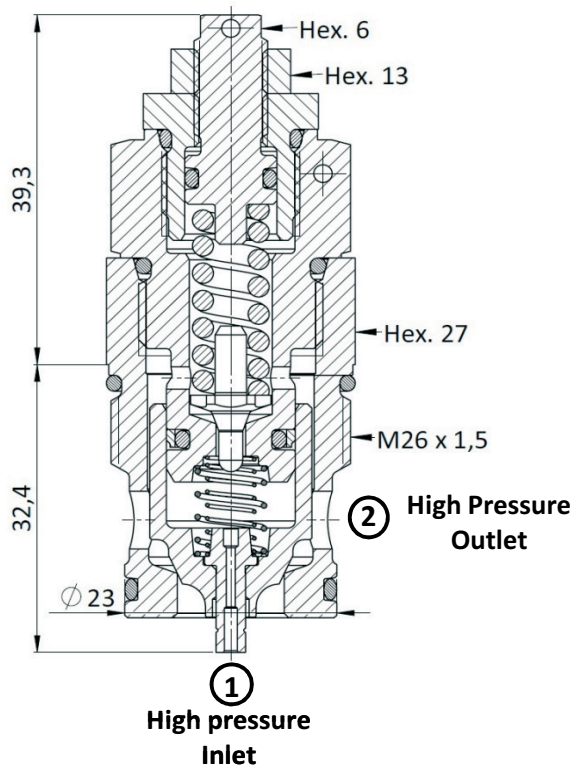

To secure the setting, torque the Hex13 nut with 15-20 Nm

Cavity Details

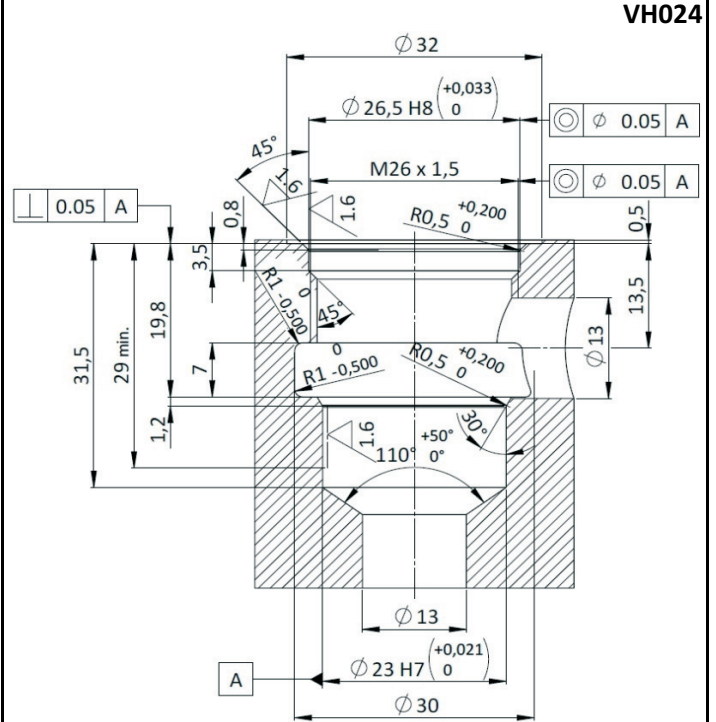

See Page 280

Ordering Code

R V P 0 . **M 2 6** . **0 N** . *** * ***

Valve Basic Code

Options

5 = Seal Lock
See cross section below.

Cavity

M26 = Metric M26 x 1.5
UNF cavity available upon request

Marking

0 = Standard factory marking
Customized markings can be done upon request

Pressure setting in [bar]

000 = no specific setting required

Spring Range (10 - 420bar)

Options

