

RVC0.S10 Valve Series

SAE10 Cartridge - 350 bar

Direct acting - Poppet Type

Description

A screw-in, cartridge style, direct acting, poppet type, normally closed hydraulic relief valve. It's typically used to protect hydraulic components from pressure transients. When the pressure at the Inlet (1) reaches the valve setting, the valve starts to open to tank (2) throttling flow to minimize the pressure rise.

The innovative geometry of the deflector provides in fact a very low rise rate, and the poppet design guarantees great stability.

The cartridge offers quick response to load changes in hydraulic circuits requiring low internal leakage as well as limited hysteresis.

NOTE: the RVC0 in the standard configuration can be used in cross-over relief applications (back pressure on port 2).

Technical Features

All external surfaces are zinc plated and corrosion-proof.

All valve parts are made of high strength steel. Poppet is hardened and ground to guarantee minimal wear and to extend service life.

Adjustment screw cannot be backed out of the valve.

Positive stop prevents springs from going solid.

Optional spring ranges to 350 bar (5000 psi)

Back pressure on the tank port (port 2) is directly additive to the valve setting at a 1:1 ratio.

Industry common cavity.



Symbols

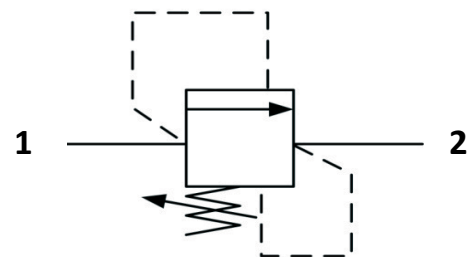

Performance Details

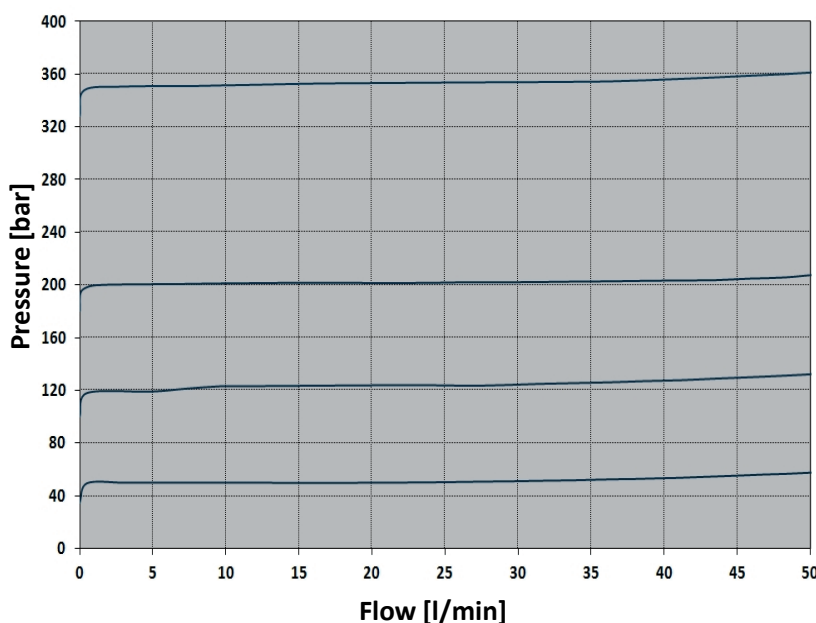

Technical Data

Maximum operating pressure: 350 bar

Maximum flow: 50 l/min

Maximum internal leakage: 0.25 cc/min to 80% of nominal set point

Factory pressure settings established @ 5 l/min

Reseat pressure: nominal 90% of crack pressure

Temperature: -30°C to 110°C

Fluids: Mineral-based or synthetics with lubricating properties at viscosities of 7.4 to 420 cSt

Orientation: no restrictions

Installation torque: 55-65 Nm

Seal kit code: SK.001

Weight: 0.17 kg

NOTE: The performance chart illustrates flow handling capacity at maximum setting for each spring range option.

P/Q curves are recorded at $T_{oil} = 40^{\circ}C$ and 46 cSt

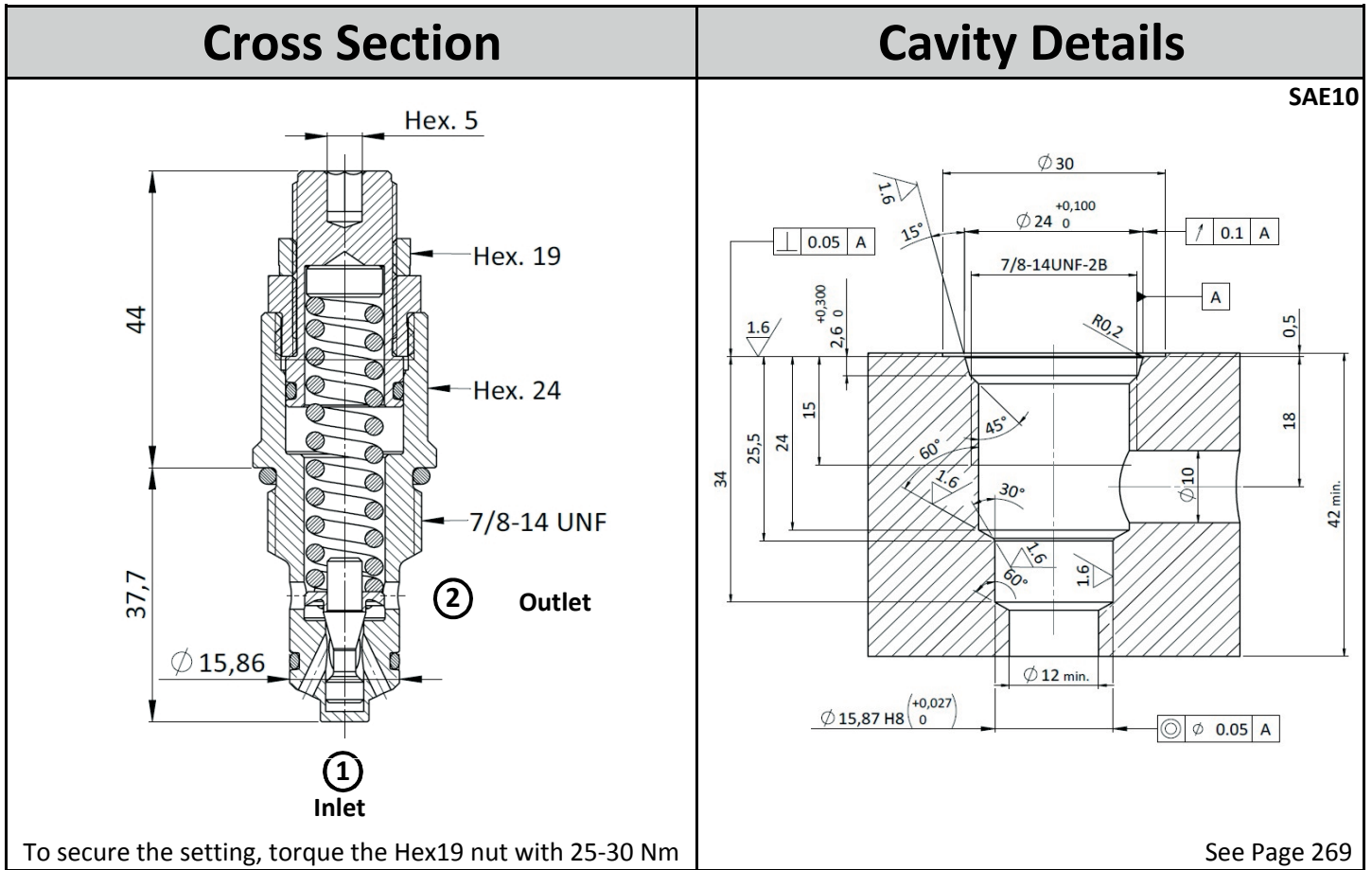

Ordering Code

R	V	C	0	.	S	1	0	.	0	*	.	*	*	*	
↓					↓				↓			↓			
Valve Basic Code					Cavity				Marking			Pressure setting in [bar]			
					S10 = UNF - SAE10 Metric cavity available upon request				0 = Standard factory marking Customized markings can be done upon request			000 = no specific setting required Spring Range (see table below for available options)			

Spring Ranges		Design Notes	Options
Spring Model Code	Optimized (Total) p Set Range [bar]	<p style="text-align: center;">3,7</p> <p>The nose of the valve protrudes by 3.7mm into ID 12mm of the cavity.</p>	<p>Plastic tamper proof cap. 2 pieces are needed to build 1 complete cap. Ordering code: CTP.001</p>
Y	15-50 (15-60)		
N	51-120 (25-135)		
B	121-200 (50-220)		
G	201-350 (120-350)		

Specifications may change without notice.