

Pilot Check Valves

PCR0.S08 Valve Series

SAE Cartridge - 350 bar

Direct acting check valve - Pilot Spool to open

Description

Cartridge style, Normally closed, single pilot check valve.
 Cartridge is closed until sufficient pressure is applied on port 2 to reach the bias spring setting, push the poppet and allow free flow to 1.
 The valve is normally closed from 1 to 2.
 When sufficient pressure is applied on port 3, the pilot spool pushes the poppet from its seat and allows flow from 1 to 2.
 Very limited leakage in the check condition.

Technical Features

All external surfaces are zinc plated and corrosion-proof.
 All valve parts are made of high strength steel. Poppet is hardened and ground to guarantee minimal wear and to extend service life.
 Pilot spool is hardened and ground, sealed to prevent leakage.
 High durometer, extrusion resistant seals.
 Optional bias springs for back-pressure application flexibility.
 Industry SAE common cavity.



vis hydraulics

Symbols

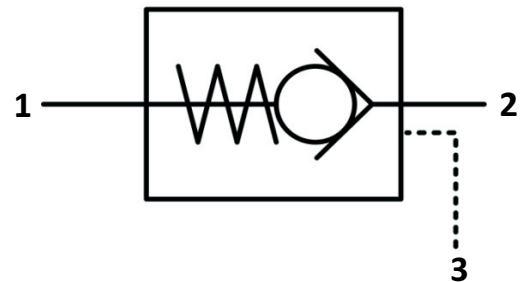

Performance Details

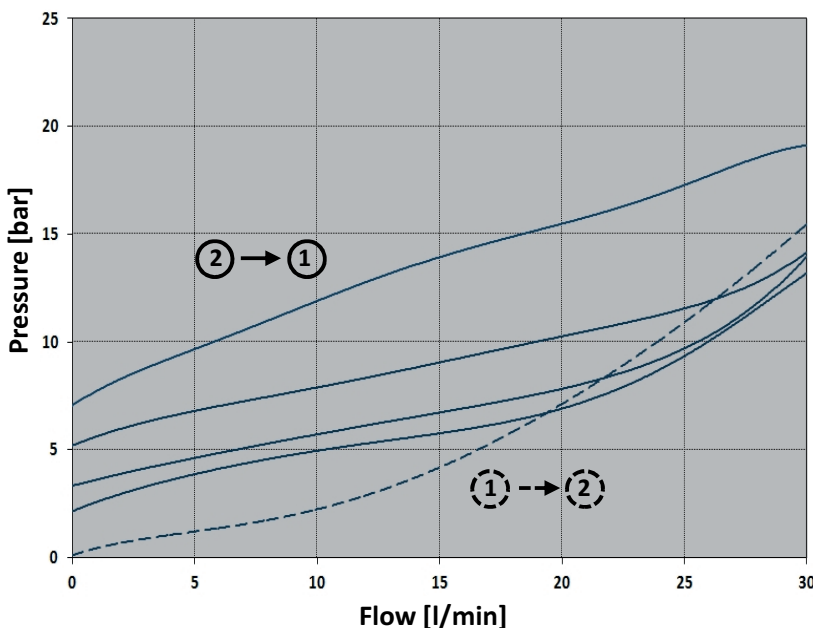

Technical Data

Maximum operating pressure: 350 bar
 Maximum flow: 30 l/min
 Internal leakage: 0.10 cc/min max @ 350 bar
 Pilot ratio 3:1
 Temperature: -30°C to 110°C
 Fluids: Mineral-based or synthetics with lubricating properties at viscosities of 7.4 to 420 cSt
 Orientation: no restrictions
 Installation torque: 40-45 Nm
 Seal kit code: SK.047
 Weight: 0.075 kg

NOTE: The performance chart illustrates flow handling capacity each spring bias option.
 P/Q curves are recorded at $T_{oil} = 40^{\circ}C$ and 46 cSt

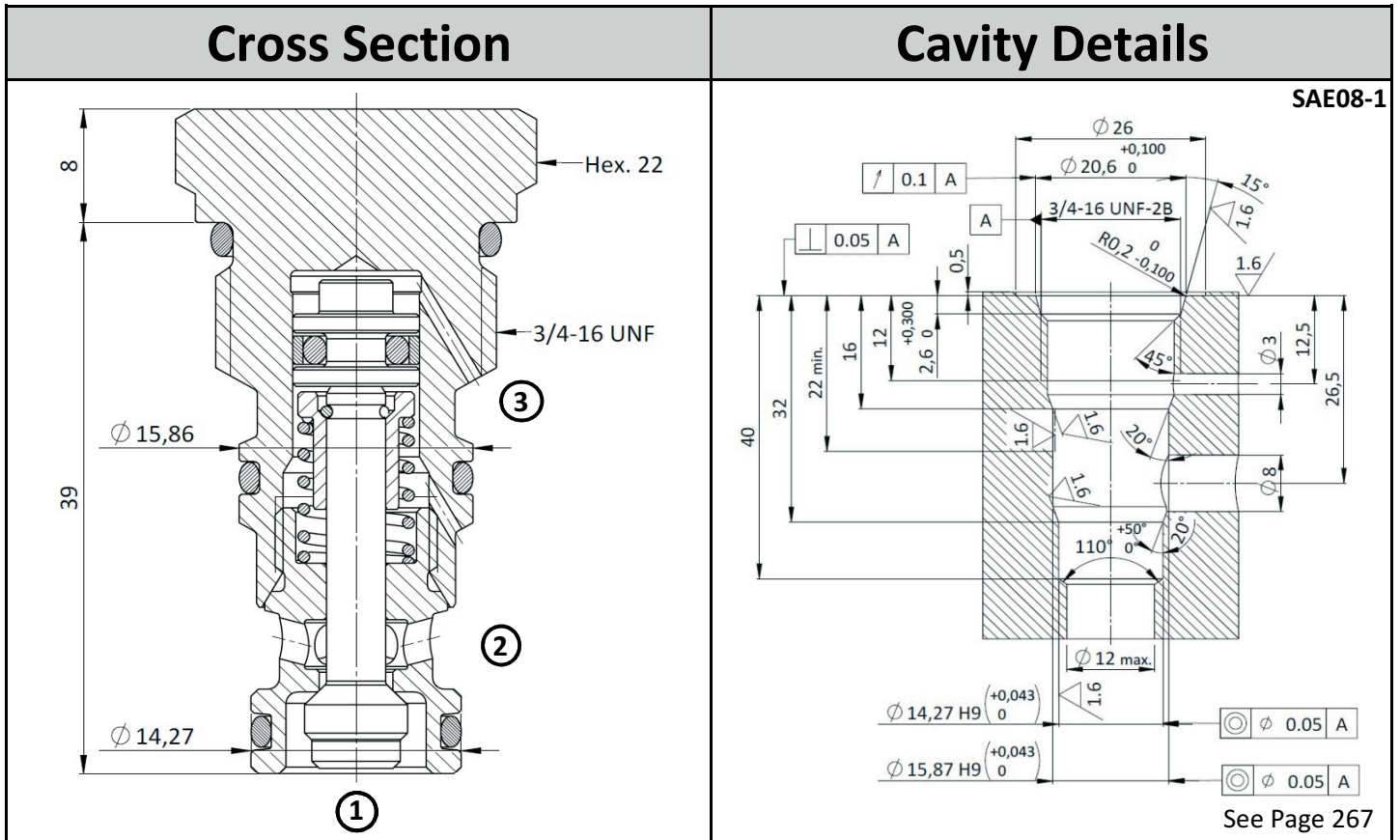

Ordering Code

P
C
R
0
.
S
0
8
.
0
*
.
0
0
0

Valve Basic Code

Options

4 = Without O-ring on the pilot spool

Cavity

S08 = UNF - SAE08-1
Metric cavity available upon request

Bias Spring (see table below for available options)

Marking 0 = Standard factory marking
Customized markings can be done upon request

000 = standard configuration

Bias Spring Options	
Spring Model Code	Cracking pressure [bar]
Y	2
N	3
B	5
G	7

Specifications may change without notice.