

# Relief and Anti-cavitation Valves

## IRR0.M16 Valve Series

**METRIC Cartridge - 350 bar**

**Direct acting with anti-cavitation - Poppet Type**

### Description

The IRR valve combines in one compact insert cartridge the typical function of shock relief valve and anticavitation through the check valve. In the pressure relief function it's a side-in nose-exhaust valve, with very low pressure rise thanks to the smart deflector design.

When the pressure at the high pressure inlet (1) reaches the valve setting, the valve starts to open to tank (2).

In the free reverse flow function a very light bias spring allows for ease of flow passage from nose to side (2 to 1).

High precision machining guarantees quick response to load changes, limited hysteresis and reduced internal and external leakage.

### Technical Features

All external surfaces are zinc plated and corrosion-proof.

All valve parts are made of high strength steel. Both internal and external poppets are hardened and ground to guarantee minimal wear and to extend service life.

Pressure setting is ADJUSTABLE.

Optional spring ranges to 350 bar (5000 psi)

Back pressure on the tank port (port 2) is directly additive to the valve setting at a 1:1 ratio.

Metric cavity.

1-piece design



## Symbols

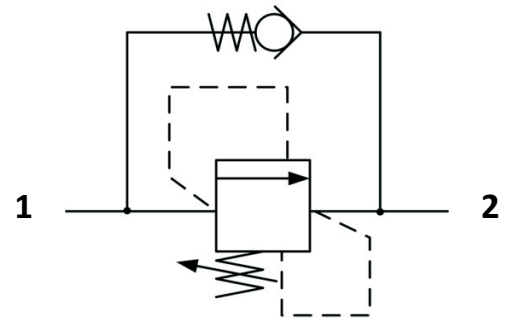

## Performance Details

**Pressure Relief function  
(side to nose)**

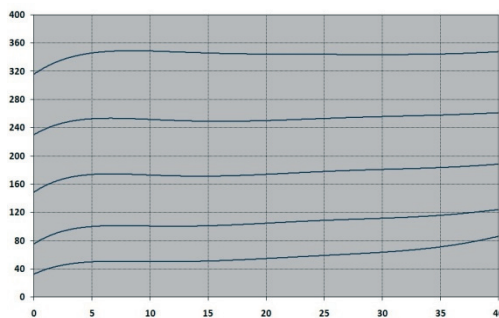

**Anti-cavitation function  
(nose to side)**

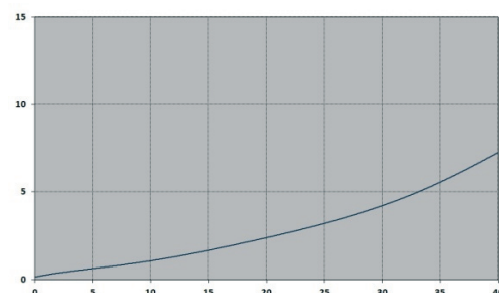

### Technical Data

Maximum operating pressure: 350 bar

Maximum flow: 40 l/min

Maximum internal leakage: 1.00 cc/min to 80% of nominal set point

Reseat pressure: nominal 90% of crack pressure

Anti-cav cracking pressure: <0.5 bar

Temperature: -30°C to 110°C

Fluids: Mineral-based or synthetics with lubricating properties at viscosities of 7.4 to 420 cSt

Orientation: no restrictions

Installation torque: 25-30 Nm

Seal kit code: SK.008

Weight: 0.100 kg

NOTE: The performance chart illustrates flow handling capacity at maximum setting for each spring range option.

P/Q curves are recorded at  $T_{oil} = 40^\circ\text{C}$  and 46 cSt

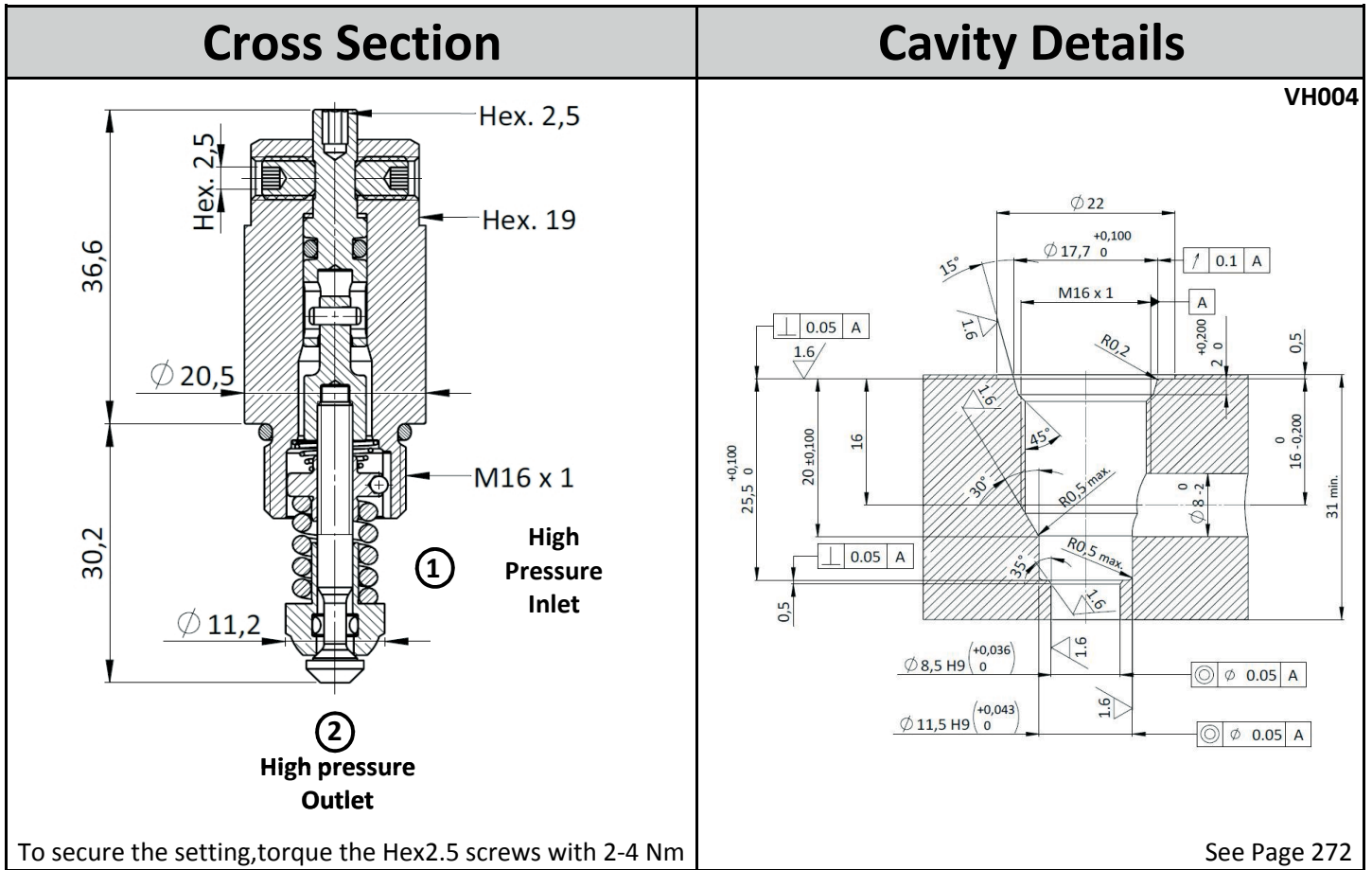

## Ordering Code

I	R	R	0	.	M	1	6	.	0	*	.	0	0	0
---	---	---	---	---	---	---	---	---	---	---	---	---	---	---

↓
↓
↓
↓
↓
↓
↓
↓
↓
↓
↓
↓
↓
↓
↓

**Valve Basic Code**  
**Cavity** ← M16 = Metric M16 x 1 UNF cavity available upon request  
**Spring Range** (see table below for available options)  
**Marking** 0 = Standard factory marking  
 Customized markings can be done upon request

Spring Ranges				Options
Spring Model Code	Pressure Setting Range [bar]	Spring Model Code	Pressure Setting Range [bar]	<p style="font-size: small; margin-top: 10px;"><b>Coining Kit:</b> In order to minimize external leakage we recommend to coin the cavity using the tool shown above, Code: <b>CK.001</b> Create a chamfer of 0.10 - 0.15 mm</p>
<b>N</b>	10-50	<b>V</b>	171-250	
<b>B</b>	51-100	<b>W</b>	251-350	
<b>G</b>	101-170			

Specifications may change without notice.