

FRS0.G38 Valve Series

GAS Cartridge - 250 bar

Direct acting - Pressure Compensated

Description

A direct acting, screw-in insert type, 2-way pressure compensated flow control valve.

The flow rate of this valve in the 1 to 2 flow path is largely independent of the system pressure and is determined by the dimension of a calibrated orifice.

The valve cannot be adjusted for variable flow output.

Free flow in the 2 to 1 path is allowed and not pressure compensated

Technical Features

External surfaces are oxide burnished and corrosion-protected.

All valve parts are made of high strength steel. Spool is hardened and ground to guarantee low wear and to extend service life.

Suitable for heavy duty applications.

Extremely compact size.

GAS cavity.



vis hydraulics

Symbols

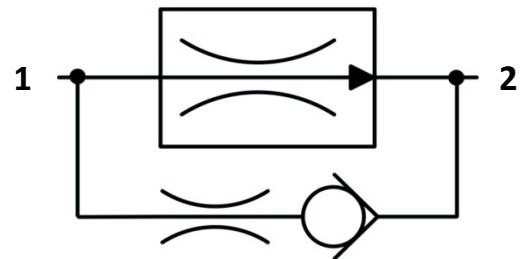

Performance Details

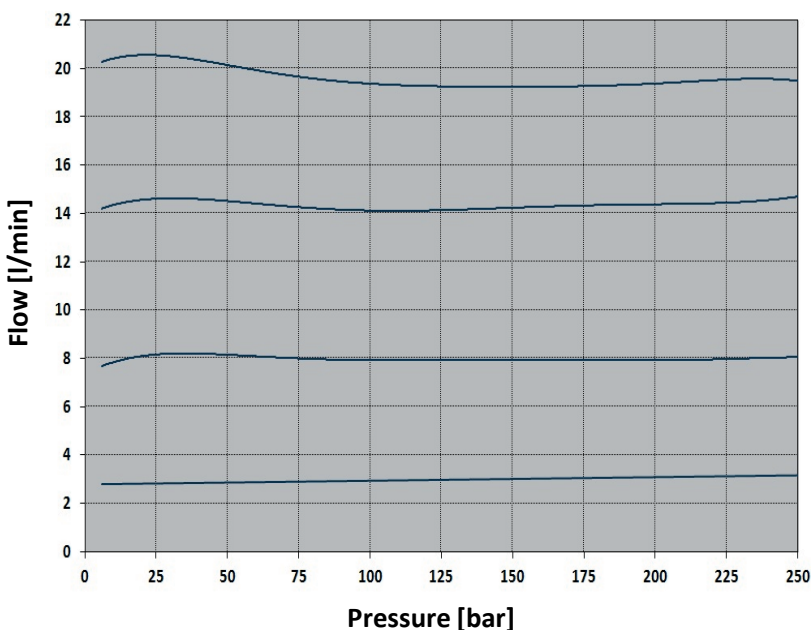

Technical Data

Maximum operating pressure: 250 bar

Maximum pressure compensated flow: 20 l/min

Temperature: -30°C to 110°C

Fluids: Mineral-based or synthetics with lubricating properties at viscosities of 7.4 to 420 cSt

Orientation: no restrictions

Installation torque: 5-8 Nm

Weight: 0.027 kg

NOTE: The performance chart illustrates flow handling capacity in the pressure compensated mode for a few significant flow settings.

P/Q curves are recorded at $T_{oil} = 40^\circ\text{C}$ and 46 cSt

Cross Section

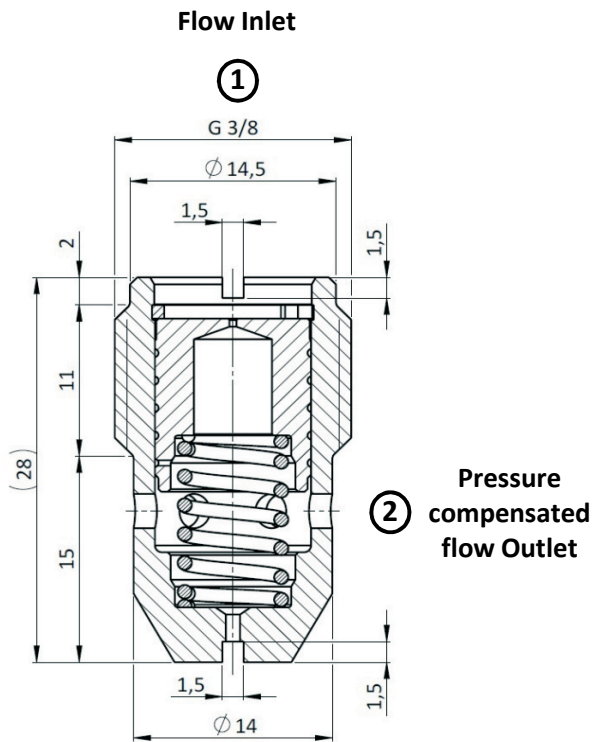

Cavity Details

VH052

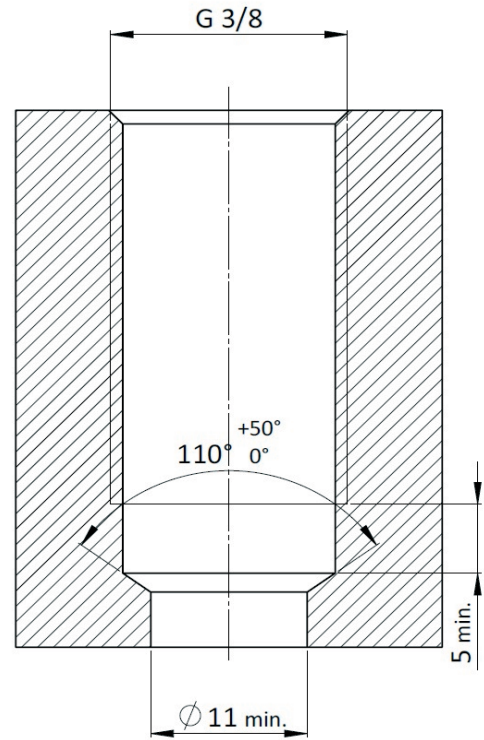

See Page 283

Ordering Code

F R S 0 . **G 3 8** . **0 N** . *** * ***

Valve Basic Code

Cavity

G38 = GAS G3/8

UNF or Metric cavities

available upon request

Fixed Flow setting (l/min with 1 decimal)

See table below for standard fixed flow options

Customized fixed flows can be provided upon request.

Flow setting options

3 l/min	030	16 l/min	160
4 l/min	040	18 l/min	180
5 l/min	050	20 l/min	200
6 l/min	060		
7 l/min	070		
8 l/min	080		
10 l/min	100		
11 l/min	110		
12 l/min	120		
14 l/min	140		

Specifications may change without notice.