

CVD0.G18 Valve Series

GAS Cartridge - 350 bar

Direct acting - Poppet Type

Description

A screw-in, direct acting, poppet type in-line check valve.

Main use is as a blocking or load-holding device.

The CVD0.G18 allows flow passage from port 1 to 2: the cartridge has a guided check which is spring-biased closed until sufficient pressure is applied at port 1 to open to 2.

The flow is blocked in the opposite direction (2 to 1).

Technical Features

External surfaces are oxide burnished and corrosion-protected.

All valve parts are made of high strength steel. Poppet and seat are hardened and ground to guarantee low wear and to extend service life

Suitable for heavy duty applications.

Extremely compact size.

GAS cavity.



vis hydraulics

Symbols



Performance Details

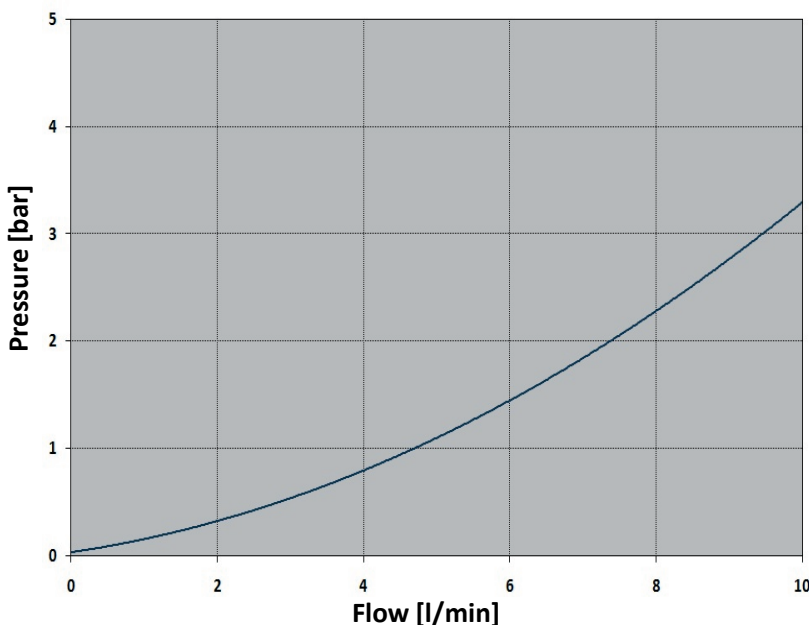

Technical Data

Maximum operating pressure: 350 bar

Maximum flow: 10 l/min

Leakage: 0.10 cc/min max @ 350 bar

Temperature: -30°C to 110°C

Fluids: Mineral-based or synthetics with lubricating properties at viscosities of 7.4 to 420 cSt

Orientation: no restrictions

Installation torque: 5 Nm

Seal kit code: SK.013

Weight: 0.002 kg

NOTE: The performance chart illustrates flow handling capacity.

P/Q curve is recorded at $T_{oil} = 40^\circ\text{C}$ and 46 cSt

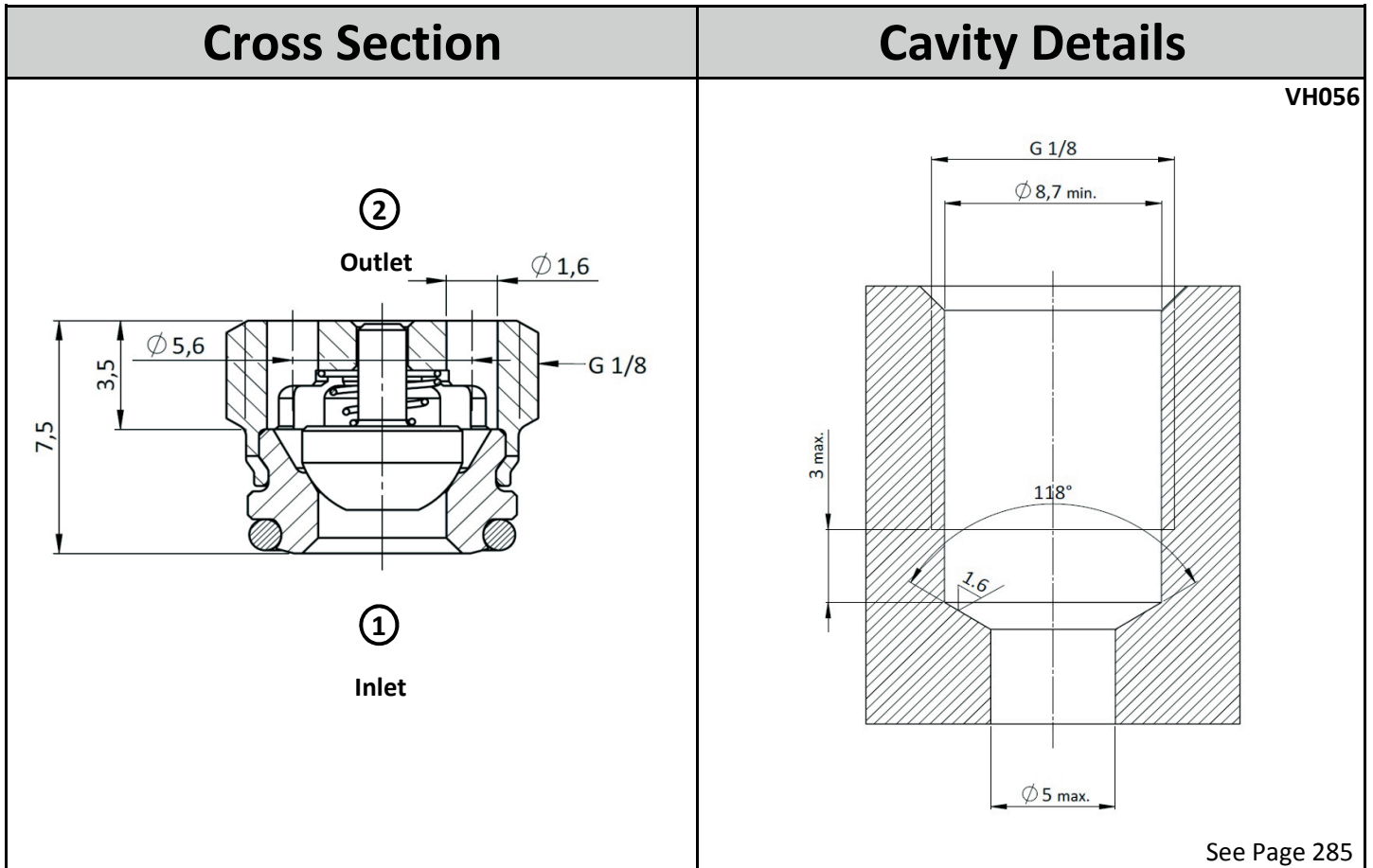

Ordering Code

C
V
D
0
.
G
1
8
.
0
N
.
0
0
0

↓
Valve Basic Code

← **Cavity**
G18 = GAS G1/8
 UNF or Metric cavities are available upon request

→ **000** = standard configuration

→ **Bias Spring** **N** = standard (cracking pressure <0.5 bar)

Bias Spring Options		Options
<p>Customized bias springs can be offered upon request.</p>		<p style="text-align: center;">Installation Tool: IK.004</p>

Specifications may change without notice.